

---

# Physics 208 - Exam II

Fall 2017 (all sections)    October 16<sup>th</sup>, 2017.

---

Please fill out the information and read the instructions below, but  
**do not open the exam** until told to do so.

Rules of the exam:

1. You have 75 minutes (1.25 hrs) to complete the exam.
2. Formulae are provided to you with the exam on a separate sheet. Make sure you have one before the exam starts. You may not use any other formula sheet.
3. Check to see that there are 6 numbered (3 double-sided) pages plus a blank page for additional work if needed, in addition to the scantron-like cover page. Do not remove any pages.
4. If you run out of space for a given problem, the last page has been left blank and may be used for extra space. Be sure to indicate at the problem under consideration that the extra space is being utilized so the graders know to look at it!
5. You will not be allowed to use calculators on this exam since all problems use symbols in their problem statements or the numbers have been chosen to make any required arithmetic calculations straightforward. If there are problems resulting in numerical answers you may leave them in fractional form.
6. **NOTE** that you **must** show your work clearly to receive full credit.
7. Cell phone use during the exam is strictly prohibited. Please turn off all ringers as calls during an exam can be quite distracting.
8. Be sure to put a box around your final answer(s) and clearly indicate your work. Credit can be given only if your work is legible, clearly explained, and labelled.
9. All of the questions require you show your work and reasoning.
10. Have your TAMU ID ready when submitting your exam to the proctor.

**Fill out the information below and sign to indicate your understanding of the above rules**

Name: \_\_\_\_\_ UIN: \_\_\_\_\_  
(printed legibly)

Signature: \_\_\_\_\_ Section Number: \_\_\_\_\_

Instructor:    Mioduszewski                      Kocharovskaya                      Saslow (**circle one**)

- A. The circuit shown in the figure below consists of a battery, a resistor and an ideal ammeter and voltmeter. When switch  $S$  is open, the voltmeter  $V$  reads  $V_1$ . When the switch is closed, the voltmeter reading drops to  $V_2$ , and the ammeter reads  $I_2$ . (i) State the requirements for the resistances of the ideal ammeter and voltmeter. (ii) What is the circuit resistance  $R$  and emf  $\mathcal{E}$ ? (Express your answers in terms of known values  $V_1$ ,  $V_2$ , and  $I_2$  ONLY.)

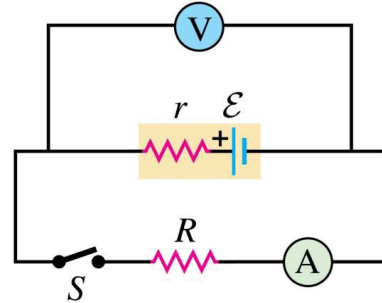

LO	P	F
36.1		
37.1		
39.1		
44.1		

- B. An ideal battery that has emf of  $\mathcal{E}$  is connected to a resistor  $R$  by two cylindrical conductors. The conductors are made of a material that has resistivity of  $\rho$ . The cylinders have the same length  $L$ , but ratio of their cross-sectional areas is 3. What is the cross-sectional area of the smaller cylindrical conductor if the current through the resistor  $R$  is  $I$ ? (Express your answer in terms of known values  $I$ ,  $\mathcal{E}$ ,  $R$ ,  $\rho$ , and  $L$ .)

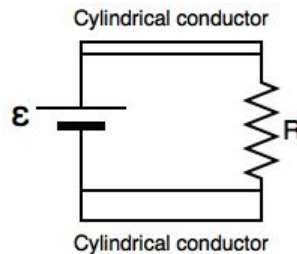

LO	P	F
3.1		
5.1		
35.1		
36.2		
41.1		

- C. An air capacitor is made of two square parallel plates with a side of length  $a$  separated by a distance  $d$  and has charge  $Q$  on its plates. It is disconnected from the battery, and subsequently a rectangular block with dimensions  $a \times a/2 \times d$  that is made of a material with dielectric constant  $K$  is inserted into the capacitor. What is the voltage across the plates of this capacitor after the block was inserted?

LO	P	F
28.1		
30.1		
32.1		
34.1		

- D. The circuit shown in the figure below consists of two resistors  $R_1$  and  $R_2$ , an ideal battery  $\mathcal{E}$  and a capacitor  $C$ . What is the current through the resistor  $R_1$  (i) *immediately after* the switch is closed and (ii) *very long time after* the switch is closed in the circuit shown below? (Express your answer in terms of known values  $C$ ,  $\mathcal{E}$ ,  $R_1$ , and  $R_2$ .)

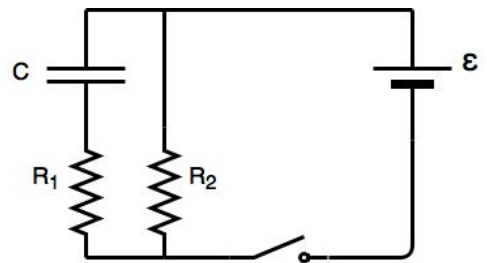

LO	P	F
43.1		
45.1		
45.2		

### Problem I.

Two capacitors having capacitances of  $C_1$ , and  $C_2$  are connected in series across a potential difference of  $V_o$ .

A. What is the charge on capacitor  $C_1$ ?

B. What is the total energy stored in the two capacitors together?

C. The capacitors are disconnected from the potential difference without allowing them to discharge. They are then reconnected in parallel with each other, with the positively charged plates connected together. What is the voltage across each capacitor in the parallel combination?

LO	P	F
28.2		
28.3		
30.2		
30.3		
30.4		
30.5		
31.1		

Problem II.

The circuit shown in the figure below consists of four identical resistors  $R = 5 \Omega$  and three identical ideal batteries that have emf  $\mathcal{E} = 5 \text{ V}$ .

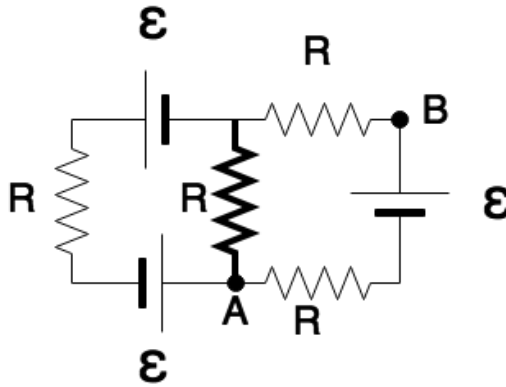

- A. What is the current through the resistor  $R$  located in the center of the circuit (it is highlighted by a bold line)?

LO	P	F
3.2		
4.1		
42.1		
42.2		
43.2		
43.3		
43.4		
43.5		

- B. What is the potential across points **A** and **B**?

Problem III.

In the circuit shown below both capacitors are initially charged and have potential difference  $V$  across the plates.

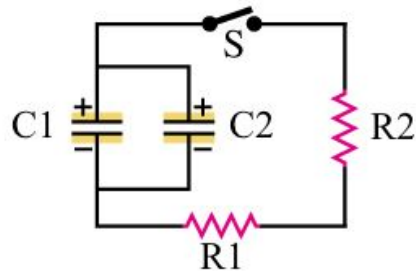

- A. How long after closing the switch  $S$  will the potential across each capacitor be reduced to  $V/3$ ?
- B. What will be the current through the resistor  $R_1$  at that time?
- C. What is the total energy stored in the capacitors at that time?

LO	P	F
3.3		
30.6		
31.2		
36.3		
41.2		
41.3		
45.3		