

---

# Physics 208 - Exam III

Fall 2018 (525-528; 531-535; 561-565) November 12, 2018.

---

Please fill out the information and read the instructions below, but  
**do not open the exam** until told to do so.

Rules of the exam:

1. You have 75 minutes (1.25 hrs.) to complete the exam.
2. Formulae are provided to you with the exam on a separate sheet. Make sure you have one before the exam starts. You may not use any other formula sheet.
3. Check to see that there are 6 numbered (3 double-sided) pages plus a blank page for additional work if needed, in addition to the scantron-like cover page. Do not remove any pages.
4. If you run out of space for a given problem, the last page has been left blank and may be used for extra space. Be sure to indicate at the problem under consideration that the extra space is being utilized so the graders know to look at it!
5. You will be allowed to use only non-programmable calculators on this exam.
6. **NOTE** that you **must** show your work clearly to receive full credit.
7. Cell phone use during the exam is strictly prohibited. Please turn off all ringers as calls during an exam can be quite distracting.
8. Be sure to put a box around your final answer(s) and clearly indicate your work. Credit can be given only if your work is legible, clearly explained, and labelled.
9. All of the questions require you show your work and reasoning.
10. Have your TAMU ID ready when submitting your exam to the proctor.

**Fill out the information below and sign to indicate your understanding of the above rules**

Name: \_\_\_\_\_  
(please print legibly)

UIN: \_\_\_\_\_

Signature: \_\_\_\_\_

Section Number: \_\_\_\_\_

Instructor: Webb  
(circle one)

Kocharovskaya

- A. A wire of a quarter circle shape with a radius  $R$  carries a current  $I$  flowing in a clockwise direction. Find both the magnitude and direction of a magnetic field in the origin of the circle. Justify your answer.

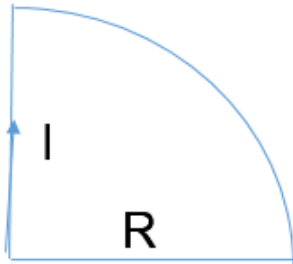

LO	P	F
1.1		
2.1		
5.1		
52.1		
2.2		
3.1		
7.1		

- B. A positively charged particle enters the region with crossed  $E$  and  $B$  as shown on the Figure. The speed of the particle is larger than  $E/B$ . In what direction would the particle deflect while exiting this region? Justify your answer.

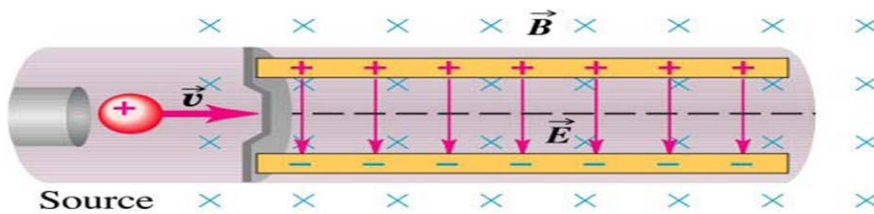

LO	P	F
2.3		
13.1		
46.1		
3.2		
48.1		

- C. An RL circuit is connected to a source of EMF through a switch ( $L = 2.0 \text{ mH}$ ,  $R = 100 \text{ } \Omega$ ,  $\mathcal{E} = 50 \text{ V}$ ). After the switch is closed answer the following:
- What are the current through the circuit and the emf across the inductor **immediately** after the switch is closed?
  - What are the current through the circuit and the emf across the inductor after the switch has been **closed for a long time**?
  - What is the characteristic time constant for this circuit?
  - What is the energy stored in the inductor after the switch has been **closed for a long time**?

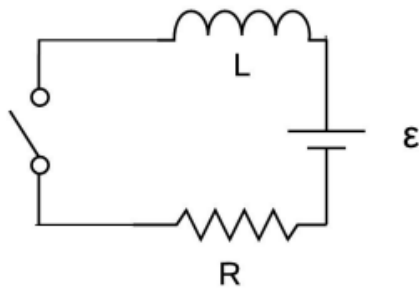

LO	P	F
43.1		
63.1		
65.1		
43.2		
65.2		
64.1		
65.3		

**Problem I.**

A long straight wire with a circular cross section with a radius,  $R$ , carries a current  $I$ . Assume that the current density in this wire is not constant across the wire, but varies as  $J(r) = \alpha r$ , where  $\alpha$  is a positive constant and  $r$  is the distance from the axis of the wire. In terms of the quantities given,  $I$ ,  $R$ , and  $\alpha$ , answer the following:

- a) Knowing that the total current in the wire must be  $I$ , find the value of the constant  $\alpha$  in terms of  $I$  and  $R$ .
- b) Find the magnitude and direction of the magnetic field  $B$  for regions inside the wire where  $r < R$ .
- c) Find the magnitude and direction of the magnetic field  $B$  outside the wire for  $r > R$ .

LO	P	F
3.3		
5.2		
7.2		
3.4		
7.3		
7.4		
54.1		
3.5		
7.5		
54.2		

**Problem II.**

The capacitor in the circuit below is initially uncharged. The switch S has been in position 1 for a **very long time**. Then it is flipped to position 2. In terms of the given quantities,  $R$ ,  $V$ ,  $L$ , and  $C$ , answer the following:

- What do the ideal ammeter and the ideal voltmeter below show just after flipping the switch?
- Sketch a graph showing the reading of the ammeter as a function of time after the switch is in position 2. Make sure to label your axes clearly.
- Find the maximum value of emf induced in inductor with an inductance  $L$ .
- What fraction of the oscillation period does it take to reach that value after flipping the switch to position 2?
- Find the maximum energy stored in the capacitor.

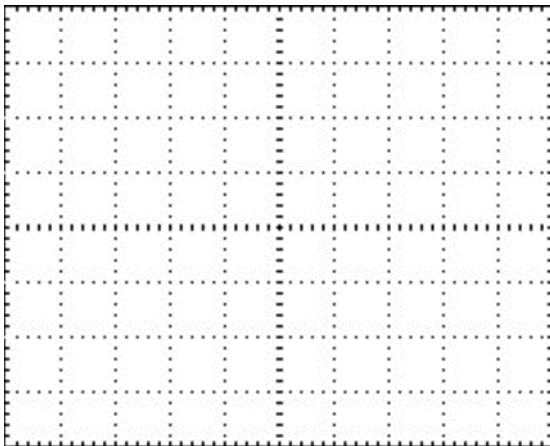
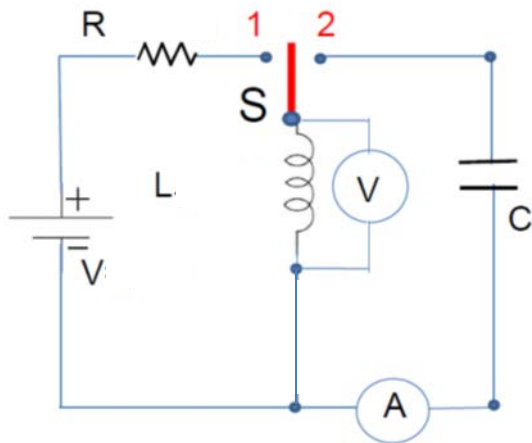

LO	P	F
43.3		
44.1		
65.4		
6.1		
66.1		
66.2		
3.6		
28.1		
31.1		
64.2		
66.3		
66.4		
31.2		
64.3		

**Problem III.**

1. A long straight wire carries a current that depends on time. The current as a function of time has the following form,  $i(t) = 10.0 \text{ A} + (0.5 \text{ A/s})t$ . Located a distance away from this wire is a square loop of wire of side length 10.0 cm as shown in the figure.

- Find the B-field as a function of the distance  $r$ , from the wire, as a function of time.
- Find the flux of the magnetic field passing through this loop for any time  $t$ .
- Find the EMF induced in the loop.
- If the loop has a resistance of  $5.0 \Omega$ , what is the magnitude and direction of the induced current? Explain your answer.
- Indicate the direction of the net magnetic force produced on a square loop by the straight wire. Explain your answer.

2. If a current in the wire is constant at 10.0 A in the direction shown but the square loop now moves with the velocity  $v = 1.0 \text{ m/s}$  parallel to the wire in the direction of the current in the wire, find the magnitude and the direction of the induced current in the loop. Explain your answer.

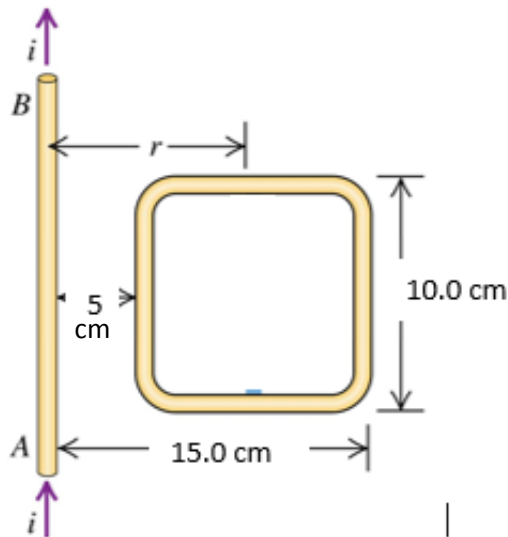

LO	P	F
54.3		
2.4		
5.3		
7.6		
56.1		
7.7		
57.1		
43.4		
58.1		
2.5		
46.2		
46.3		
46.4		
3.7		
58.2		
59.1		

