

Physics 207 – Comprehensive Exam

Sections (207-212, 543-583) – December 3rd, 2021

Right answer indicated by ←. Number of points indicated in [], zero otherwise

1. [7 pts] The plates of a parallel plate capacitor each have an area of 0.40 m^2 and are separated by a distance of 0.02 m . They are charged until the potential difference between the plates is 3000 V . The charged capacitor is then isolated. Determine the magnitude of the electric field between the capacitor plates.

- A) 60 V/m
- B) 120 V/m
- C) $1.0 \times 10^5 \text{ V/m}$
- D) $1.5 \times 10^5 \text{ V/m}$ ←
- E) $2.5 \times 10^5 \text{ V/m}$
- F) $3.0 \times 10^5 \text{ V/m}$

2. [7 pts] Two positive charges are located at points **A** and **B** as shown with $a = 2.0 \text{ m}$. The electric potential at the point **P** in the figure is

- A) $1.35 \times 10^4 \text{ V}$
- B) $1.89 \times 10^4 \text{ V}$
- C) $2.30 \times 10^4 \text{ V}$
- D) $2.70 \times 10^4 \text{ V}$ ←
- E) $3.68 \times 10^4 \text{ V}$
- F) $3.94 \times 10^4 \text{ V}$

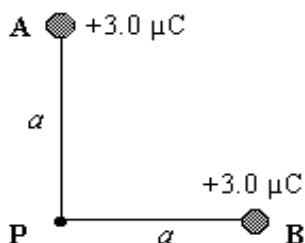

3. [7 pts] The drawing shows two long, thin wires that carry currents in the positive z direction. Both wires are parallel to the z axis. The 50-A wire is in the xz plane and is 5 m from the z axis. The 40-A wire is in the yz plane and is 4 m from the z axis. The magnitude and direction of the magnetic field at the origin is

- A) zero
- B) $2.8 \times 10^{-6} \text{ T}$, in the direction of $+\hat{x} + \hat{y}$
- C) $2.8 \times 10^{-6} \text{ T}$, in the direction of $+\hat{x} - \hat{y}$ ← [7]
- D) $2.0 \times 10^{-6} \text{ T}$, in the direction of $+\hat{x} + \hat{y}$
- E) $2.0 \times 10^{-6} \text{ T}$, in the direction of $+\hat{x} - \hat{y}$ [3]
- F) $4.0 \times 10^{-6} \text{ T}$, in the direction of $+\hat{x} + \hat{y}$

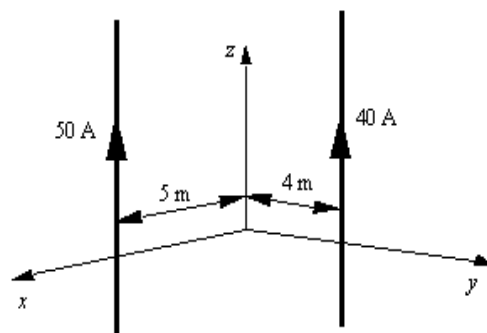

4. [7 pts] In Figure, a wire and a 10 ohm resistor are used to form a circuit in the shape of a square, 20 cm by 20 cm. A uniform but non-steady magnetic field is directed into the plane of the circuit. The magnitude of the magnetic field is decreasing at a fixed rate from 2.70 T to 0.90 T in a time interval of 96 ms. During this time interval the average induced current and its direction through the resistor are closest to

- A) 45 mA, from a to b
 B) 45 mA, from b to a
 C) 75 mA, from a to b
 D) 75 mA, from b to a ←
 E) 110 mA, from a to b
 F) 110 mA, from b to a

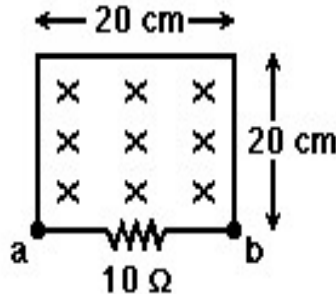

5. [7 pts] Four capacitors are arranged in the circuit shown in the figure. The capacitors have the values $C_1=25.5 \mu\text{F}$, $C_2=45.5 \mu\text{F}$, $C_3=50.5 \mu\text{F}$, and $C_4=40.5 \mu\text{F}$. What is the equivalent capacitance of the circuit?

- A) $13.9 \mu\text{F}$ ← [7]
 B) $93.5 \mu\text{F}$ [3]
 C) $162 \mu\text{F}$
 D) $91 \mu\text{F}$
 E) $71 \mu\text{F}$
 F) $10.5 \mu\text{F}$

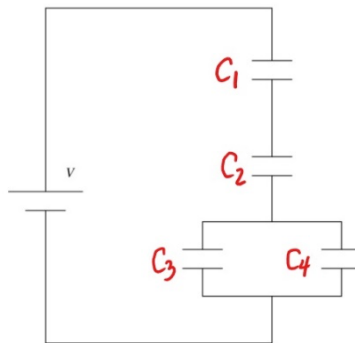

6. [7 pts] An RC circuit consists of a resistor with resistance $1.0 \text{ k}\Omega$, a 120-V battery, and two capacitors, C_1 and C_2 , with capacitances of $20 \mu\text{F}$ and $60 \mu\text{F}$, respectively. Initially, the capacitors are uncharged and the switch is closed at $t = 0$. What is the current through the resistor a long time after the switch is closed?

- A) 0.60 A
 B) 0.30 A
 C) 0.24 A
 D) 0.48 A
 E) 0.15 A
 F) 0.00 A ←

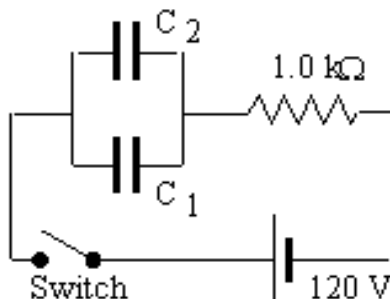

7. [7 pts] Find the value of the line integral of the magnetic field around a closed curve in the presence of six electric currents as shown in the figure: with $I_1=3.73$ A, $I_2=7.19$ A, $I_3=1.49$ A, $I_4=4.31$ A, $I_5=3.77$ A and $I_6=6.11$ A

- A) $26.6 \mu_0$
 B) $16.7 \mu_0$ [3]
 C) $7.46 \mu_0$ [3]
 D) $5.12 \mu_0$ ← [7]
 E) $-5.12 \mu_0$
 F) $-7.46 \mu_0$

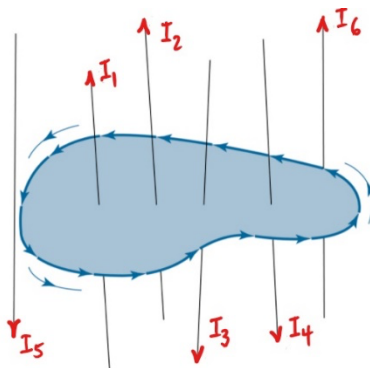

8. [7 pts] In the circuit shown, $L=4.00$ H, $V_b=24.0$ V, $R_1=80 \Omega$ and $R_2=40 \Omega$. After switch S has been closed for a long time, the current I_b through the battery and the current I_L through the inductor are respectively

- A) $I_b=0$ $I_L=0$
 B) $I_b=0.3$ A $I_L=0$
 C) $I_b=0.2$ A $I_L=0$ [3]
 D) $I_b=0.3$ A $I_L=0.3$ A ← [7]
 E) $I_b=0.2$ A $I_L=0.2$ A
 F) $I_b=0.5$ A $I_L=0.3$ A [3]

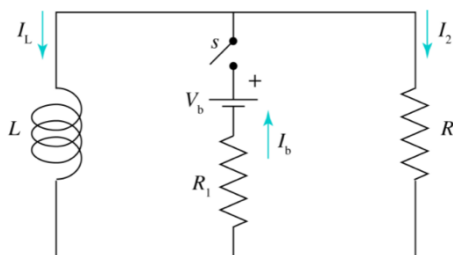

9. [7 pts] An oscillating voltage of fixed amplitude is applied across a circuit element. If the frequency of this voltage is increased, the amplitude of the current will:

- A) increase if the circuit element is either an inductor or a capacitor. [3]
 B) decrease if the circuit element is either an inductor or a capacitor. [3]
 C) remains the same for either an inductor or a capacitor.
 D) increase if the circuit element is an inductor, but decrease if the circuit element is a capacitor. [3]
 E) decrease if the circuit element is an inductor, but increase if the circuit element is a capacitor. ← [7]

10. [7 pts] In the circuit below the capacitance is $C=40.0$ mF and the inductance is $L=65.0$ H. The capacitor is fully charged when the switch S is closed. Calculate the time needed for the energy initially stored in the capacitor to be completely transferred to the inductor.

- A) 10.13 s [3]
 B) 5.06 s [5]
 C) 2.53 s ← [7]
 D) 1.26 s
 E) 0.63 s
 F) 0.32 s

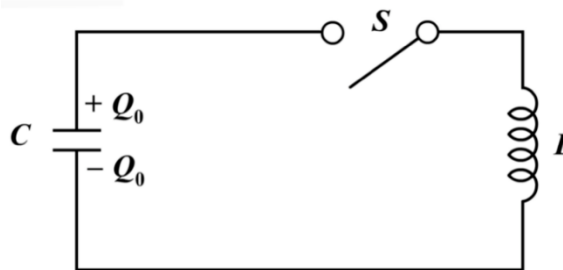

11. [7 pts] An electromagnetic plane wave is propagating in free space toward the negative x direction. The magnetic field is as shown. A possible description of the electric field is:

- A) $\vec{E} = E_0 \cos(kx + \omega t) \hat{x}$
 B) $\vec{E} = E_0 \cos(kx - \omega t) \hat{x}$
 C) $\vec{E} = E_0 \sin(kx + \omega t) \hat{z}$ [3]
 D) $\vec{E} = E_0 \sin(kx - \omega t) \hat{z}$
 E) $\vec{E} = E_0 \cos(kx + \omega t) \hat{z}$ ← [7]
 F) $\vec{E} = E_0 \cos(kx - \omega t) \hat{z}$ [4]

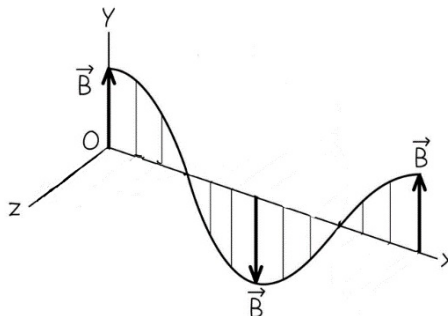

12. [8 pts] An electromagnetic plane wave has its magnetic field oscillating parallel to the z axis and has a Poynting vector given by $\vec{S}(x, t) = \frac{100 \text{ W}}{\text{m}^2} \cos^2(kx - \omega t) \hat{x}$.

The electric field must be given by

- A) $\vec{E} = \left(0.011 \frac{\text{V}}{\text{m}}\right) \cos(kx - \omega t) \hat{y}$ [2]
 B) $\vec{E} = \left(0.011 \frac{\text{V}}{\text{m}}\right) \cos(kx - \omega t) \hat{z}$
 C) $\vec{E} = \left(10 \frac{\text{V}}{\text{m}}\right) \cos(kx - \omega t) \hat{y}$ [4]
 D) $\vec{E} = \left(10 \frac{\text{V}}{\text{m}}\right) \cos(kx - \omega t) \hat{z}$
 E) $\vec{E} = \left(194 \frac{\text{V}}{\text{m}}\right) \cos(kx - \omega t) \hat{y}$ ← [8]
 F) $\vec{E} = \left(194 \frac{\text{V}}{\text{m}}\right) \cos(kx - \omega t) \hat{z}$ [4]

13. [7 pts] In the following diagram $R_1 = R_2 = R_3 = R$ and $V_a = 4\varepsilon$, $V_b = \varepsilon$.

In terms of R and V , the magnitudes of current I_1 and I_2 flowing through resistors R_1 and R_2 must be respectively

- A) $|I_1| = 1\varepsilon/R$ $|I_2| = 3\varepsilon/R$
 B) $|I_1| = 2\varepsilon/R$ $|I_2| = 2\varepsilon/R$
 C) $|I_1| = 3\varepsilon/R$ $|I_2| = \varepsilon/R$ ← [7]
 D) $|I_1| = 4\varepsilon/R$ $|I_2| = 2\varepsilon/R$
 E) $|I_1| = 3\varepsilon/R$ $|I_2| = 3\varepsilon/R$
 F) $|I_1| = 2\varepsilon/R$ $|I_2| = \varepsilon/R$ [3]

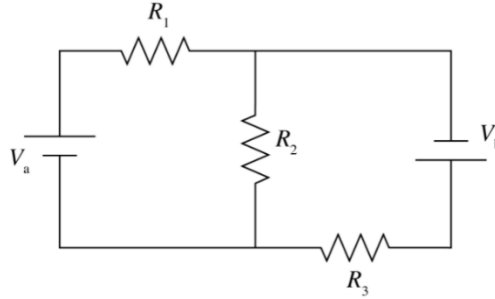

14. [8 pts] Two uniformly charged solid spheres of total charge $-Q$ and Q with radius R are placed along the x -axis with centers at $x=0$ and $x=2R$ respectively. The electric field produced by both charged sphere at $x=R/2$ is

- A) $\vec{E} = +k \frac{Q}{R^2} \left(\frac{1}{2} + \frac{1}{4} \right) \hat{x}$
 B) $\vec{E} = -k \frac{Q}{R^2} \left(\frac{1}{2} + \frac{1}{4} \right) \hat{x}$ [4]
 C) $\vec{E} = +k \frac{Q}{R^2} \left(\frac{4}{9} + \frac{1}{2} \right) \hat{x}$
 D) $\vec{E} = -k \frac{Q}{R^2} \left(\frac{4}{9} + \frac{1}{2} \right) \hat{x}$ ← [8]
 E) $\vec{E} = +k \frac{Q}{R^2} \left(\frac{4}{9} + \frac{1}{4} \right) \hat{x}$
 F) $\vec{E} = -k \frac{Q}{R^2} \left(\frac{4}{9} + \frac{1}{4} \right) \hat{x}$ [4]

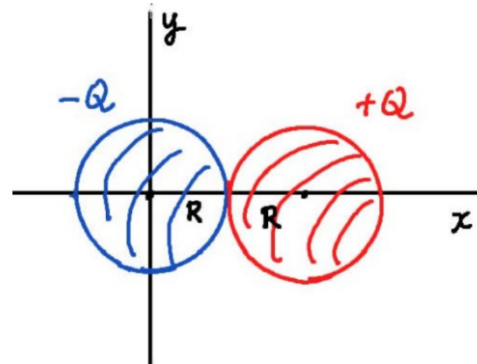

Scratch Paper

Scratch Paper