Physics 207 – Comprehensive Exam

Fall 2019- November 25, 2019.

Please fill out the information and read the instructions below, but
do not open the exam until told to do so.

Rules of the exam:

1. You have 120 minutes (2.0 hrs.) to complete the exam.
2. Formulae are provided to you with the exam on a separate sheet. Make sure you have one before the exam starts. You may not use any other formula sheet.
3. Check to see that there are 8 numbered (4 double-sided) pages plus a blank page for additional work if needed, in addition to the scantron-like cover page. Do not remove any pages.
4. If you run out of space for a given problem, the last page has been left blank and may be used for extra space. **Be sure to indicate at the problem under consideration that the extra space is being utilized so the graders know to look at it!**
5. You will be allowed to use only non-programmable calculators on this exam.
6. **NOTE** that you **must** show your work clearly to receive full credit.
7. Cell phone use during the exam is strictly prohibited. Please turn off all ringers as calls during an exam can be distracting.
8. Be sure to put a box around your final answer(s) and clearly indicate your work. Credit can be given only if your work is legible, clearly explained, and labelled.
9. All of the questions require you show your work and reasoning.
10. Have your TAMU ID ready when submitting your exam to the proctor.

Fill out the information below and sign to indicate your understanding of the above rules

Name: _____

UIN: _____

(please print legibly)

Signature: _____

Section Number: _____

Instructor: Webb Saslow Kocharovskaya Eusebi

- A.** Two small plastic spheres are 20.0 cm apart. Consider the spheres to be point charges. One sphere has a charge of magnitude three times that of the other sphere. The force between them is 0.25 N and attractive.
- i.)** Find the charge on each sphere if the sphere with the larger charge is positive.
 - ii.)** If the smaller charge were absent, find the electric field due to the larger charge at the location of the smaller charge. Give both magnitude and direction.

LO	P	F
8.1		
3.1		
5.1		
10.1		
3.2		

- B.** An electric field points along the x -axis with $E_x = -3x^2 + 6x$ for E_x in volts/m and x in meters.
- i.)** Compute $V(x)$ for this electric field, if $V(0) = 2.0$ V.
 - ii.)** Sketch $V(x)$ for the x -interval (-1.0 m, 1.0 m)

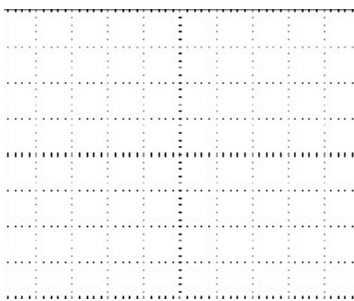

LO	P	F
7.1		
26.1		
27.1		
3.3		

C. The region of uniform magnetic field in a mass spectrometer (a device to measure the mass of an ion) is pictured below.

- i.) What are the signs of the charges of the two ions whose paths are plotted?
- ii.) If these two ions have the same charge, which mass m_1 or m_2 is bigger?
Explain your results using words and supporting equations.

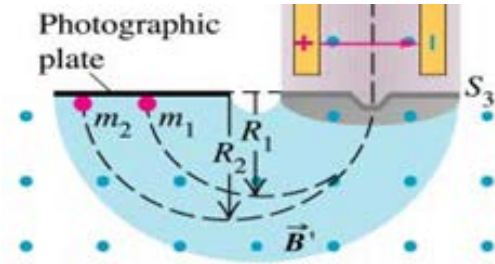

Uniform B field out of the page

LO	P	F
2.1		
3.4		
46.1		
47.1		
48.1		

- D. A long, straight, solid wire has radius R with cross-sectional view shown below. A current I flows along the wire, into the page, and is distributed uniformly over the wire's cross-section (see Xs in figure). Find the magnitude and the direction of the magnetic field at the point P (inside the wire), which is **half way** ($R/2$) between the center line of the wire and the top edge of the wire.

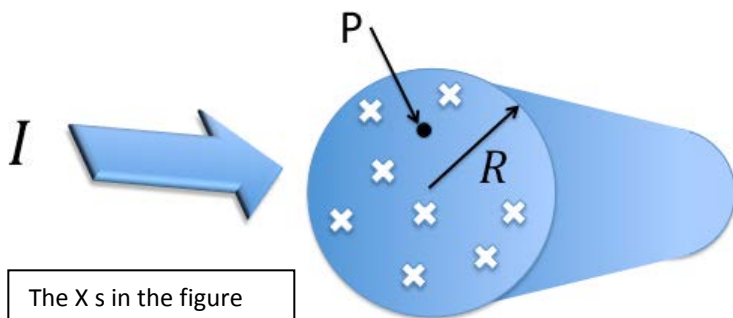

LO	P	F
2.2		
3.5		
5.2		
7.2		
54.1		
55.1		

The X s in the figure represent the direction of the current flow in the conductor.

E. In the circuit below, the capacitor is initially uncharged. The switch **S** is closed at $t=0$. Answer the following in terms of the quantities, R_1 , R_2 , \mathcal{E} and C .

- i.) What is the initial voltage across the capacitor?
- ii.) What are the initial currents through each resistor and the capacitor?
- iii.) What are currents through each resistor and the capacitor after the switch is closed for a long time?
- iv.) What is the voltage across the capacitor in the long time limit?
- v.) Considering R_1 as the internal resistance of the battery, find the terminal voltage of the battery in the long time limit.

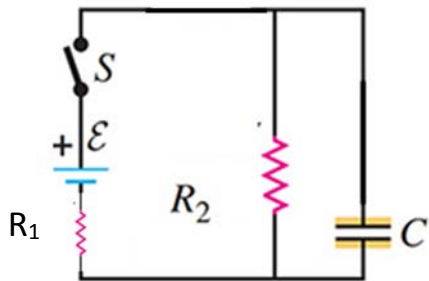

LO	P	F
28.1		
43.1		
45.1		
43.2		
45.2		
43.3		
45.3		
43.4		
39.1		
43.5		

- F.** Consider a series R-L-C circuit with $R = 60.0 \, \Omega$, $L = 0.40 \, \text{H}$, and $C = 4.00 \times 10^{-4} \, \text{F}$. The AC source has a voltage amplitude of $90.0 \, \text{V}$ and an angular frequency of $240 \, \text{rad/sec}$. (**Note:** you do not have to punch these numbers into your calculator to get full credit. Please indicate the algebraic expressions that you intend to evaluate for each question below with the numbers in the expression.)
- i.)** Find the impedance of this circuit.
 - ii.)** What is the maximum current that flows in this circuit?
 - iii.)** What is the phase angle between the current and the voltage supply?

LO	P	F
68.1		
36.1		
36.2		
68.2		

Problem 1. A solid insulating sphere of radius R is surrounded by a thin conducting spherical shell of radius $2R$. The thin conducting shell has a total charge $-Q$.

- Find the uniform charge density on the insulating sphere to give zero E-field outside the conducting shell.
- Draw field lines in the region for $R < r < 2R$, assuming the charge density of part a) is actually on the insulator.
- Using the charge density from part a), find an expression for the electric field as a function of r for $r < R$.
- Using this charge density from part a), find an expression for the electric field as a function of r for $R < r < 2R$.
- For what value of the radial distance, r , is the energy density of the electric field the largest?

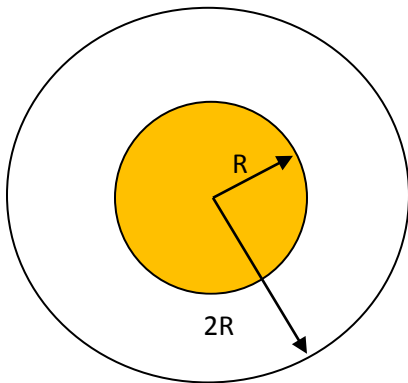

LO	P	F
5.3		
7.3		
13.1		
7.4		
18.1		
18.2		
31.1		
5.4		

Problem 2. A local radio station broadcasts at a frequency of 104.7 MHz. Further, this station transmits a total of 50 kW of radio power uniformly in all directions *above the Earth's surface*.

- a) What is the wavelength associated with this broadcast station?
- b) Find the intensity at a distance of 2.5 km from the antenna.
- c) Find the amplitude of the E-field at this distance.
- d) For radiation traveling upward along the y-axis, the instantaneous electric field is at a maximum and points along the z-direction. Find the magnitude and direction of the instantaneous magnetic field.

LO	P	F
71.1		
73.1		
73.2		
71.2		
71.3		
3.6		

Problem 3. A square wire loop is located in the xy -plane. It is in a region of uniform magnetic field, $B(t) = 10.0\text{ T} + (0.5\text{ T/s})t$ into the page. Answer the following:

- Find the flux of the magnetic field passing through this loop for any time t .
- Find the EMF induced in the loop.
- If the loop has a resistance of $5.0\ \Omega$, what is the magnitude and direction of the induced current?

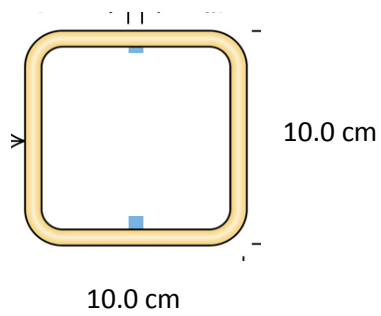

LO	P	F
56.1		
7.5		
57.1		
60.1		
58.1		
36.3		
3.7		

Left Blank for extra work space