Physics 208 - Exam III

Spring 2019 (513-517; 520-524) April 8, 2019.

Please fill out the information and read the instructions below, but
do not open the exam until told to do so.

Rules of the exam:

1. You have 75 minutes (1.25 hrs.) to complete the exam.
2. Formulae are provided to you with the exam on a separate sheet. Make sure you have one before the exam starts. You may not use any other formula sheet.
3. Check to see that there are 7 numbered pages plus a blank page for additional work if needed (5 double-sided including the bubble sheet). Do not remove any pages.
4. If you run out of space for a given problem, the last page has been left blank and may be used for extra space. Be sure to indicate at the problem under consideration that the extra space is being utilized so the graders know to look at it!
5. **You will be allowed to use only non-programmable calculators on this exam.**
6. **NOTE** that you **must** show your work clearly to receive full credit.
7. Cell phone use during the exam is strictly prohibited. Please turn off all ringers as calls during an exam can be quite distracting.
8. Be sure to put a box around your final answer(s) and clearly indicate your work. Credit can be given only if your work is legible, clearly explained, and labelled.
9. All of the questions require you show your work and reasoning.
10. Have your TAMU ID ready when submitting your exam to the proctor.

Fill out the information below and sign to indicate your understanding of the above rules

Name: _____

UIN: _____

Signature: _____

Section Number: _____

Instructor: **Ross**

Webb

(circle one)

- A)** For a long solenoid, suppose the current is increasing with time. Which of the following is a true statement regarding this situation? (Choose one.)
- (i) The increase in current will be balanced by a decrease in the displacement current, giving no change in the magnetic field inside the solenoid.
 - (ii) Faraday's law shows that there will be electric fields that circulate within the solenoid.
 - (iii) The electric field will point along the axis of the solenoid, parallel to the magnetic field lines.
 - (iv) Lenz's law tells us that the increasing current will cause a corresponding decrease in the energy stored in the solenoid.
 - (v) The electric field will be zero; only a magnetic field will be produced.
- B)** Choose the correct statement:
- (i) The magnetic force on a straight segment of wire always points in the same direction as the current flowing in the segment.
 - (ii) The total magnetic flux through a closed surface is proportional to the total electric charge inside.
 - (iii) A charged particle at rest in a uniform B field will be accelerated in a direction perpendicular to the B field lines.
 - (iv) In a magnetic field, the kinetic energy of a moving electron will steadily increase.
 - (v) A current-carrying loop of wire tends to line up with its plane perpendicular to the direction of an applied magnetic field.

LO	P	F
57.1		
50.1		

- C) A slide wire of mass m and large resistance R , moves with a constant velocity v , on a rectangular loop of width L in a magnetic field B as shown in the figure.
- (i.) State the direction of the induced current that arises due to this motion and give a reason for your answer.
- (ii.) Find the direction of the magnetic force acting on the slide wire. Again give a reason for your choice.

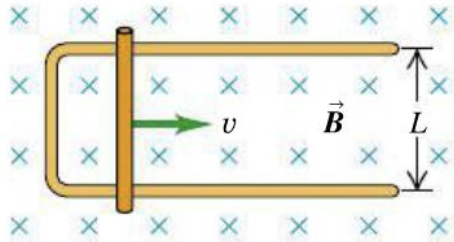

- D) A positively charged particle with a charge of Q and mass m enters a region of uniform magnetic field with B_o pointing in the $+z$ direction. The charged particle has a velocity of $\vec{V} = 3v_o \hat{i} + 4v_o \hat{j}$, where v_o is positive. In terms of the quantities given, answer the following:
- (i.) Find the magnetic force on this charged particle as it enters the magnetic field?
- (ii.) What is the radius of the trajectory that this particle makes in this magnetic field?

LO	P	F
57.2		
58.1		
49.1		
2.1		
46.1		
2.2		
46.2		
48.1		

- E) The figure shows a magnetic field pointing perpendicular to the plane of the loop, and in a direction out of the page, with its magnitude uniform everywhere. The circular loop has a radius of 0.1 m, and wires with negligible resistance other than the inserted resistor with $R = 20 \Omega$. Neglect the area of the extra non-circular part of the loop which connects to the resistor.
- (i.) If the magnetic field doubles from 3.0 T to 8.0 T at a constant rate in 0.5 s, find the current through the resistor during this time.
- (ii.) In which direction will this current flow during the time the field is changing, and why?

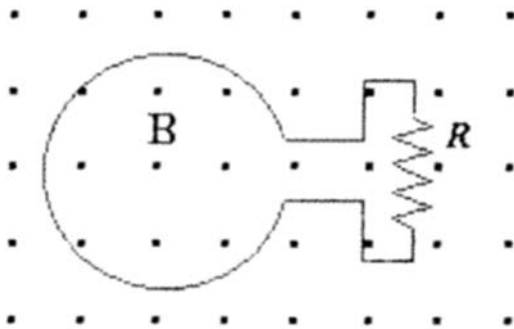

- F) For the circuit shown below, the switch is closed at time $t=0$ and remains closed for later times.
- (i.) Which of the five labeled curves most accurately depicts the emf appearing across the inductor as a function of time? (choose one)
- (ii.) Find the time constant for this circuit if $L = 1.5 \mu\text{H}$ and $R = 3.0 \text{ k}\Omega$.
- (iii.) If the value of the emf in the circuit is 10 V, find the energy stored in the inductor after the switch is closed for a long time.

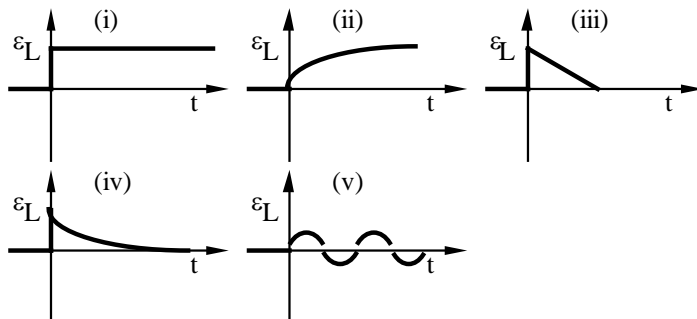
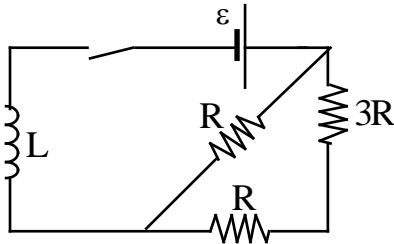

LO	P	F
56.1		
57.3		
3.1		
58.2		
41.1		
65.1		
65.2		
3.2		
43.1		
64.1		

Problem 1. You are asked to find the magnetic field at the origin produced by the loop of wire in the figure below.

- (a) Which principle/law will you need to use to find this magnetic field:
- Ampere's Law.
 - Faraday's Law
 - Biot-Savart's Law.
 - Gauss's Law.
 - Coulomb's Law.
- (b) Find the value of the magnetic field (magnitude and direction) produced by the current loop in the figure.

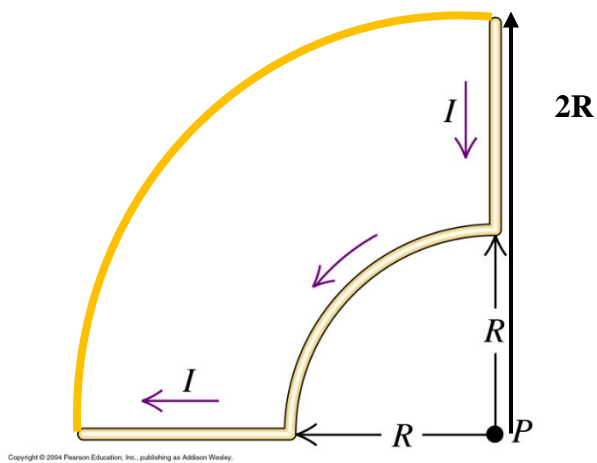

LO	P	F
52.1		
5.1		
2.3		
1.1		
7.1		
52.2		
3.3		

Problem 2. Shown is a cut-away view of a long cable. The inner conductor of this cable is a thin wire carrying current $2I$ upwards. The outer conductor is a long, thick shell carrying total current $3I$ downward, between radii $R/2$ and R . (Note: the current is uniform in the shell, $R/2 < r < R$, not just on its outer surface.) Inside radius $R/2$ is hollow except for the very thin center wire.

(a.) The magnetic field of this cable system can be found most easily using (choose one):

- a. Gauss's Law
- b. Faraday's Law
- c. Ampere's Law
- d. Biot-Savart's Law
- e. Coulomb's Law

(b.) Using the law selected in a) find the magnetic field in the hollow region for $r < R/2$ (please show your work and give magnitude and direction).

(c.) Find the magnetic field in the outer conductor for a position $R/2 < r < R$, as a function of r and give the direction of the field at $r = R/2$ and $r = R$.

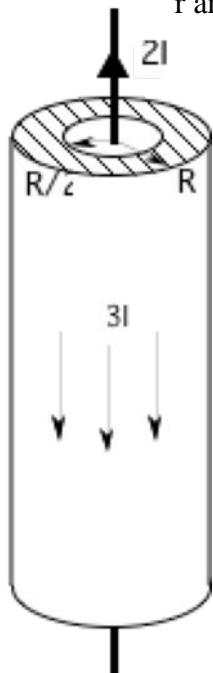

LO	P	F
55.1		
2.4		
7.2		
54.1		
7.3		
54.2		
2.5		
3.4		

Problem 3. In the circuit shown, the inductor and battery are ideal (no resistance), and the switch is opened at time $t = 0$, **after having been closed for a long time**.

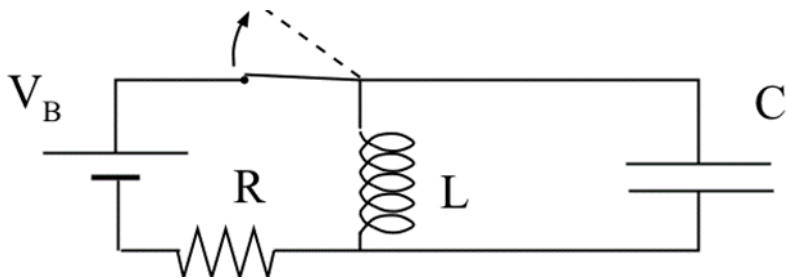

- (a) Before the switch is opened, and after the switch has been connected for a long time, what is the emf across the inductor?
- (b) What energy is stored in the inductor before the switch is opened, if $V_B = 12.0 \text{ V}$, $R = 6.0 \Omega$, $L = 8.0 \text{ mH}$, and $C = 1200 \mu\text{F}$?
- (c) After opening the switch, what is the peak value of energy that will be stored in the capacitor at later times? (Use the values of the parameters given in part (b)).
- (d) Find the period of oscillation, T , of this circuit. (Again use the parameter values given in part (b)).
- (e) Find the current in the inductor at time $t = T/2$ after the switch is opened. Make sure you note both its magnitude and its direction.

LO	P	F
63.1		
65.3		
43.2		
64.2		
31.1		
64.3		
66.1		
66.2		