

Students: (only) fill out this section

Clearly write your 9-digit UIN in the square boxes to the right and completely fill in the numerical bubble below each digit. Also, enter your name (as it appears on your TAMU ID), your section number, and your instructor's name below.

First name: _____

Last name: _____

Section: _____ Instructor: _____

0	0	0	0	0	0	0	0	0	0
1	1	1	1	1	1	1	1	1	1
2	2	2	2	2	2	2	2	2	2
3	3	3	3	3	3	3	3	3	3
4	4	4	4	4	4	4	4	4	4
5	5	5	5	5	5	5	5	5	5
6	6	6	6	6	6	6	6	6	6
7	7	7	7	7	7	7	7	7	7
8	8	8	8	8	8	8	8	8	8
9	9	9	9	9	9	9	9	9	9

Graders: (only) fill out this section

Completed:

A	B	C	D	1	2	3	4
---	---	---	---	---	---	---	---

- | | | |
|---------------------------------|---------------------------------|---------------------------------|
| 1. (1) (2) (3) (4) (5) (6) (7) | 26. (1) (2) (3) (4) (5) (6) (7) | 51. (1) (2) (3) (4) (5) (6) (7) |
| 2. (1) (2) (3) (4) (5) (6) (7) | 27. (1) (2) (3) (4) (5) (6) (7) | 52. (1) (2) (3) (4) (5) (6) (7) |
| 3. (1) (2) (3) (4) (5) (6) (7) | 28. (1) (2) (3) (4) (5) (6) (7) | 53. (1) (2) (3) (4) (5) (6) (7) |
| 4. (1) (2) (3) (4) (5) (6) (7) | 29. (1) (2) (3) (4) (5) (6) (7) | 54. (1) (2) (3) (4) (5) (6) (7) |
| 5. (1) (2) (3) (4) (5) (6) (7) | 30. (1) (2) (3) (4) (5) (6) (7) | 55. (1) (2) (3) (4) (5) (6) (7) |
| 6. (1) (2) (3) (4) (5) (6) (7) | 31. (1) (2) (3) (4) (5) (6) (7) | 56. (1) (2) (3) (4) (5) (6) (7) |
| 7. (1) (2) (3) (4) (5) (6) (7) | 32. (1) (2) (3) (4) (5) (6) (7) | 57. (1) (2) (3) (4) (5) (6) (7) |
| 8. (1) (2) (3) (4) (5) (6) (7) | 33. (1) (2) (3) (4) (5) (6) (7) | 58. (1) (2) (3) (4) (5) (6) (7) |
| 9. (1) (2) (3) (4) (5) (6) (7) | 34. (1) (2) (3) (4) (5) (6) (7) | 59. (1) (2) (3) (4) (5) (6) (7) |
| 10. (1) (2) (3) (4) (5) (6) (7) | 35. (1) (2) (3) (4) (5) (6) (7) | 60. (1) (2) (3) (4) (5) (6) (7) |
| 11. (1) (2) (3) (4) (5) (6) (7) | 36. (1) (2) (3) (4) (5) (6) (7) | 61. (1) (2) (3) (4) (5) (6) (7) |
| 12. (1) (2) (3) (4) (5) (6) (7) | 37. (1) (2) (3) (4) (5) (6) (7) | 62. (1) (2) (3) (4) (5) (6) (7) |
| 13. (1) (2) (3) (4) (5) (6) (7) | 38. (1) (2) (3) (4) (5) (6) (7) | 63. (1) (2) (3) (4) (5) (6) (7) |
| 14. (1) (2) (3) (4) (5) (6) (7) | 39. (1) (2) (3) (4) (5) (6) (7) | 64. (1) (2) (3) (4) (5) (6) (7) |
| 15. (1) (2) (3) (4) (5) (6) (7) | 40. (1) (2) (3) (4) (5) (6) (7) | 65. (1) (2) (3) (4) (5) (6) (7) |
| 16. (1) (2) (3) (4) (5) (6) (7) | 41. (1) (2) (3) (4) (5) (6) (7) | 66. (1) (2) (3) (4) (5) (6) (7) |
| 17. (1) (2) (3) (4) (5) (6) (7) | 42. (1) (2) (3) (4) (5) (6) (7) | 67. (1) (2) (3) (4) (5) (6) (7) |
| 18. (1) (2) (3) (4) (5) (6) (7) | 43. (1) (2) (3) (4) (5) (6) (7) | 68. (1) (2) (3) (4) (5) (6) (7) |
| 19. (1) (2) (3) (4) (5) (6) (7) | 44. (1) (2) (3) (4) (5) (6) (7) | 69. (1) (2) (3) (4) (5) (6) (7) |
| 20. (1) (2) (3) (4) (5) (6) (7) | 45. (1) (2) (3) (4) (5) (6) (7) | 70. (1) (2) (3) (4) (5) (6) (7) |
| 21. (1) (2) (3) (4) (5) (6) (7) | 46. (1) (2) (3) (4) (5) (6) (7) | 71. (1) (2) (3) (4) (5) (6) (7) |
| 22. (1) (2) (3) (4) (5) (6) (7) | 47. (1) (2) (3) (4) (5) (6) (7) | 72. (1) (2) (3) (4) (5) (6) (7) |
| 23. (1) (2) (3) (4) (5) (6) (7) | 48. (1) (2) (3) (4) (5) (6) (7) | 73. (1) (2) (3) (4) (5) (6) (7) |
| 24. (1) (2) (3) (4) (5) (6) (7) | 49. (1) (2) (3) (4) (5) (6) (7) | 74. (1) (2) (3) (4) (5) (6) (7) |
| 25. (1) (2) (3) (4) (5) (6) (7) | 50. (1) (2) (3) (4) (5) (6) (7) | 75. (1) (2) (3) (4) (5) (6) (7) |

Correction indicator(s):

Grading correction explanation:

(1) (2) (3) (4) (5)

THIS PAGE IS INTENTIONALLY LEFT BLANK

Physics 208 - Exam II

Spring 2019 (513-517; 520-524) March 4, 2019.

Please fill out the information and read the instructions below, but
do not open the exam until told to do so.

Rules of the exam:

1. You have 75 minutes (1.25 hrs.) to complete the exam.
2. Formulae are provided to you with the exam on a separate sheet. Make sure you have one before the exam starts. You may not use any other formula sheet.
3. Check to see that there are 7 numbered pages plus a blank page for additional work if needed (5 double-sided including the bubble sheet). Do not remove any pages.
4. If you run out of space for a given problem, the last page has been left blank and may be used for extra space. Be sure to indicate at the problem under consideration that the extra space is being utilized so the graders know to look at it!
5. You will be allowed to use only non-programmable calculators on this exam.
6. **NOTE** that you **must** show your work clearly to receive full credit.
7. Cell phone use during the exam is strictly prohibited. Please turn off all ringers as calls during an exam can be quite distracting.
8. Be sure to put a box around your final answer(s) and clearly indicate your work. Credit can be given only if your work is legible, clearly explained, and labelled.
9. All of the questions require you show your work and reasoning.
10. Have your TAMU ID ready when submitting your exam to the proctor.

Fill out the information below and sign to indicate your understanding of the above rules

Name: _____

UIN: _____

Signature: _____

Section Number: _____

Instructor: **Ross**

Webb

(circle one)

A) Two identical capacitors, C_1 and C_2 , both with the same capacitance, C , are charged using a DC power supply to Q and $2Q$ respectively. Being careful not to lose any charge in the process, they are then connected as shown in the two circuit configurations diagramed below, with the initial (unconnected) charge orientations shown by the + and – signs in the figure. In terms of the quantities given, C , Q , and other known constants, answer the following:

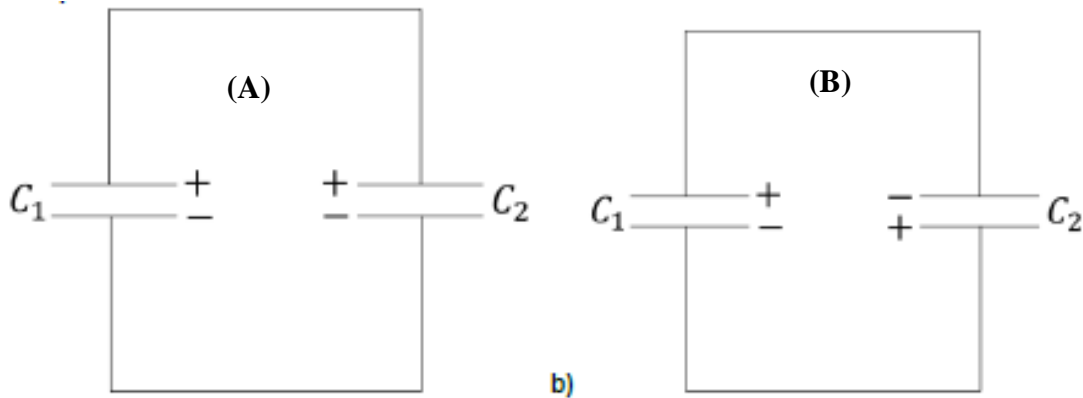

- (a) Once the charges have reached their “steady state” values what is the final charge on each capacitor in configuration A)?
- (b) What is the voltage on each capacitor in the “steady state” for configuration A)?
- (c) Once the charges have reached their “steady state” values in configuration B) what will be the final charge on each capacitor in this configuration?

LO	P	F
28.1		
30.1		
28.2		
30.2		
28.3		
30.3		

B) Three resistors are connected across an **ideal** 2.0-V DC battery as shown in the figure.

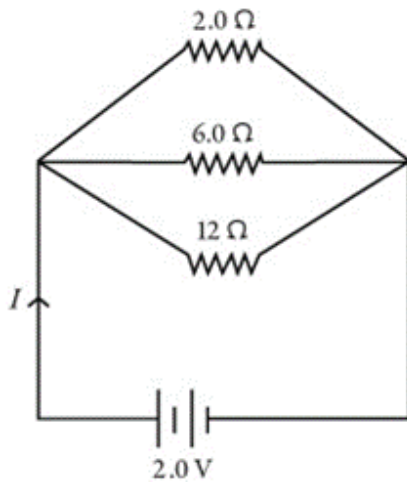

- Find the effective resistance of this three resistor network.
- Find the total current being supplied to the network by this battery.
- At what rate does the battery supply energy to the resistor network?
- What is the power being dissipated by the 6.0Ω resistor?

LO	P	F
38.1		
41.1		
36.1		
40.1		
40.2		
41.2		

C) You are given the circuit below that is attached to an 18 V battery (not shown). Initially the switch is open and the circuit has been connected to the battery for a long time.

- (a) What is the voltage difference between points a and b under these circumstances, with the switch open? Specifically, what is $V_b - V_a = ?$
- (b) What is the charge on each of the capacitors at this time (e.g. the magnitude of the charge on one of the plates of each of the capacitors)?
- (c) The switch is now closed and we again wait for a long time. What will the voltage between point b and ground be after waiting a long time?

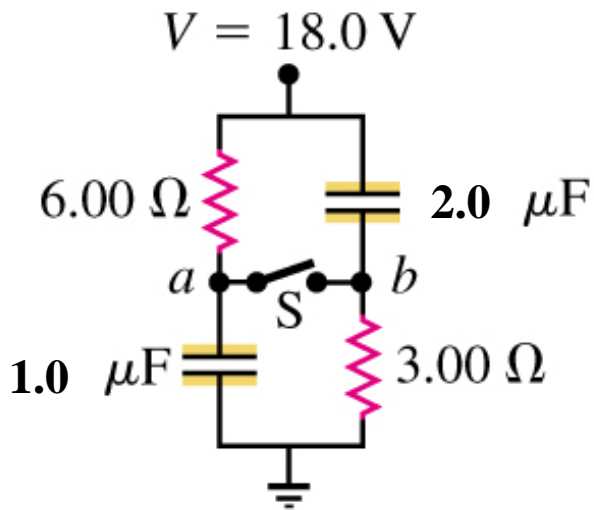

LO	P	F
38.2		
45.1		
28.4		
36.2		
41.3		

Problem 1. Three capacitors, a battery and a resistor are arranged as shown in the figure. If the capacitors (initially uncharged) are all $20\ \mu\text{F}$, $R = 10\ \Omega$ and $V = 5.0\ \text{V}$, answer the following:

- (a) Find the total charge supplied by the positive terminal of the battery after switch is closed and the circuit is allowed to come to the “steady state”.
- (b) How long does it take for the capacitors to store half of this charge?
- (c) Find the voltage drop across C_1 once the circuit reaches the “steady state”.
- (d) Find the total energy stored in the capacitors (taken all together) when they are fully charged.

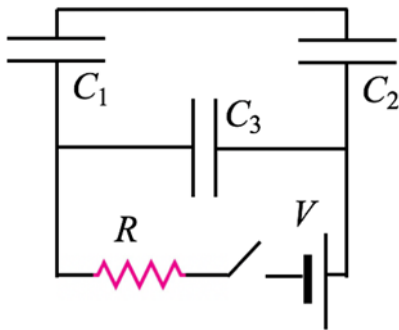

LO	P	F
28.5		
30.4		
37.1		
38.3		
45.2		
3.1		
45.3		
28.6		
30.5		
37.2		
30.6		
31.1		
40.3		

Problem 2. The circuit shown below has two batteries, both of which have internal resistances as shown and two resistors.

- Find the magnitude and direction of the current flowing in this circuit.
- Find the terminal voltages of the 16.0 V battery, $V_a - V_b$.
- Find the potential difference, $V_a - V_c$.
- Make a graph of the rising and falling of the electric potential going around the circuit using $V_b = 0$ V as your reference. **Make sure to label both axes and the points a, b, c, and d in your sketch.**

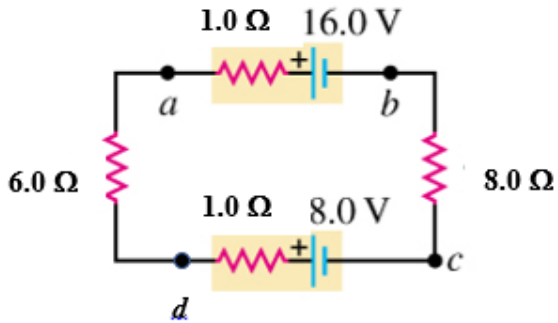

LO	P	F
3.2		
36.3		
37.3		
38.4		
41.4		
36.4		
37.4		
39.1		
36.5		
37.5		
43.1		

Problem 3. Consider the circuit in the figure below. The batteries in this circuit are “ideal” batteries. This configuration has been connected for a **very long time**. The positive battery terminals are the longer lines in the battery symbol used (the right side of V_1 and the left side of V_2). Answer the following in terms of V_1 , V_2 , R_1 , R_2 , and C :

- (a) Find the value of the “steady state” charge on the capacitor in this configuration.
- (b) Find the “steady state” current in the resistor R_1 .
- (c) Supposing that for the next two parts of the problem, c) and d) $V_1 = V_2 = V$, $R_1 = R$ and $R_2 = 2R$, find the currents flowing through R_1 and R_2 in terms of the quantities given, V , R and C .
- (d) Again in terms of the quantities given, how much power is being supplied to the circuit by the battery V_2 ?

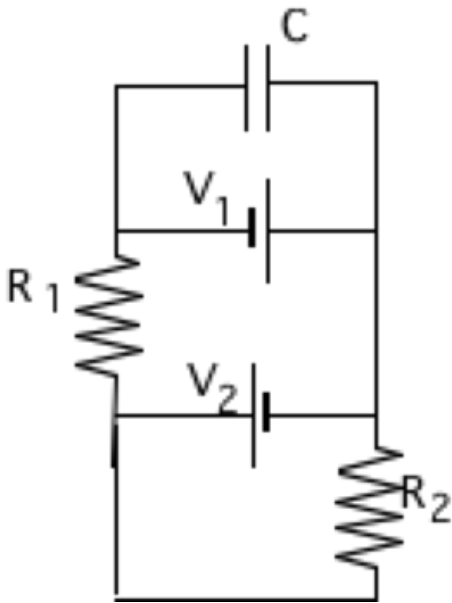

LO	P	F
28.7		
37.6		
38.5		
42.1		
43.2		
3.3		
36.6		
42.2		
43.3		
3.4		
36.7		
37.7		
43.4		
40.4		
43.5		