

# Physics 208 - Grading Sheet.

Dept. of Physics and Astronomy. TAMU.

## Marking Instructions

Fill oval completely ① ● ③ ④ ⑤

Erase cleanly ① ② ③ ④ ⑤

### Students Fill Only this information

1. First Name: \_\_\_\_\_ Last Name: \_\_\_\_\_

2. Section: \_\_\_\_\_

3. Clearly hand-write your 9-digit UIN in the square boxes at the right.

4. Then fill out the bubbles below corresponding to the digits in the UIN.

0	0	0	0	0	0	0	0	0	0
1	1	1	1	1	1	1	1	1	1
2	2	2	2	2	2	2	2	2	2
3	3	3	3	3	3	3	3	3	3
4	4	4	4	4	4	4	4	4	4
5	5	5	5	5	5	5	5	5	5
6	6	6	6	6	6	6	6	6	6
7	7	7	7	7	7	7	7	7	7
8	8	8	8	8	8	8	8	8	8
9	9	9	9	9	9	9	9	9	9

### Exam Information:

1. Fill whether this is exam 1, 2, 3 or the Final ① ② ③ ④

### Graders Fill Only this information

List of Learning Objectives: mark only those objectives achieved.

- |               |               |               |               |
|---------------|---------------|---------------|---------------|
| 1. ① ② ③ ④ ⑤  | 21. ① ② ③ ④ ⑤ | 41. ① ② ③ ④ ⑤ | 61. ① ② ③ ④ ⑤ |
| 2. ① ② ③ ④ ⑤  | 22. ① ② ③ ④ ⑤ | 42. ① ② ③ ④ ⑤ | 62. ① ② ③ ④ ⑤ |
| 3. ① ② ③ ④ ⑤  | 23. ① ② ③ ④ ⑤ | 43. ① ② ③ ④ ⑤ | 63. ① ② ③ ④ ⑤ |
| 4. ① ② ③ ④ ⑤  | 24. ① ② ③ ④ ⑤ | 44. ① ② ③ ④ ⑤ | 64. ① ② ③ ④ ⑤ |
| 5. ① ② ③ ④ ⑤  | 25. ① ② ③ ④ ⑤ | 45. ① ② ③ ④ ⑤ | 65. ① ② ③ ④ ⑤ |
| 6. ① ② ③ ④ ⑤  | 26. ① ② ③ ④ ⑤ | 46. ① ② ③ ④ ⑤ | 66. ① ② ③ ④ ⑤ |
| 7. ① ② ③ ④ ⑤  | 27. ① ② ③ ④ ⑤ | 47. ① ② ③ ④ ⑤ | 67. ① ② ③ ④ ⑤ |
| 8. ① ② ③ ④ ⑤  | 28. ① ② ③ ④ ⑤ | 48. ① ② ③ ④ ⑤ | 68. ① ② ③ ④ ⑤ |
| 9. ① ② ③ ④ ⑤  | 29. ① ② ③ ④ ⑤ | 49. ① ② ③ ④ ⑤ | 69. ① ② ③ ④ ⑤ |
| 10. ① ② ③ ④ ⑤ | 30. ① ② ③ ④ ⑤ | 50. ① ② ③ ④ ⑤ | 70. ① ② ③ ④ ⑤ |
| 11. ① ② ③ ④ ⑤ | 31. ① ② ③ ④ ⑤ | 51. ① ② ③ ④ ⑤ | 71. ① ② ③ ④ ⑤ |
| 12. ① ② ③ ④ ⑤ | 32. ① ② ③ ④ ⑤ | 52. ① ② ③ ④ ⑤ | 72. ① ② ③ ④ ⑤ |
| 13. ① ② ③ ④ ⑤ | 33. ① ② ③ ④ ⑤ | 53. ① ② ③ ④ ⑤ | 73. ① ② ③ ④ ⑤ |
| 14. ① ② ③ ④ ⑤ | 34. ① ② ③ ④ ⑤ | 54. ① ② ③ ④ ⑤ | 74. ① ② ③ ④ ⑤ |
| 15. ① ② ③ ④ ⑤ | 35. ① ② ③ ④ ⑤ | 55. ① ② ③ ④ ⑤ | 75. ① ② ③ ④ ⑤ |
| 16. ① ② ③ ④ ⑤ | 36. ① ② ③ ④ ⑤ | 56. ① ② ③ ④ ⑤ | 76. ① ② ③ ④ ⑤ |
| 17. ① ② ③ ④ ⑤ | 37. ① ② ③ ④ ⑤ | 57. ① ② ③ ④ ⑤ | 77. ① ② ③ ④ ⑤ |
| 18. ① ② ③ ④ ⑤ | 38. ① ② ③ ④ ⑤ | 58. ① ② ③ ④ ⑤ | 78. ① ② ③ ④ ⑤ |
| 19. ① ② ③ ④ ⑤ | 39. ① ② ③ ④ ⑤ | 59. ① ② ③ ④ ⑤ | 79. ① ② ③ ④ ⑤ |
| 20. ① ② ③ ④ ⑤ | 40. ① ② ③ ④ ⑤ | 60. ① ② ③ ④ ⑤ | 80. ① ② ③ ④ ⑤ |



---

# Physics 208 – Exam II

Spring 2017 (all sections)

March 6<sup>th</sup>, 2017

---

Please fill out the information and read the instructions below, but  
**do not open the exam** until told to do so.

## Rules of the exam:

1. You have 75 minutes (1.25 hrs) to complete the exam.
2. Formulae are provided to you with the exam on a separate sheet. Make sure you have one before the exam starts. You may *not* use any other formula sheet.
3. Check to see that there are 6 numbered (three double-sided) pages plus a blank page for additional work if needed, in addition to the scantron-like cover page. **Do not remove any pages.**
4. If you run out of space for a given problem, the last page has been left blank and may be used for extra space. Be sure to indicate *at the problem under consideration* that the extra space is being utilized so the graders know to look at it!
5. You will not be allowed to use calculators on this exam since all problems use symbols in their problem statements or the numbers have been chosen to make any required arithmetic calculations straight forward. If there are problems resulting in numerical answers you may leave them in fractional form.
6. **NOTE** that you **must** show your work clearly to receive full credit.
7. Cell phone use during the exam is strictly prohibited. Please turn off all ringers as calls during an exam can be quite distracting.
8. Be sure to put a box around your final answer(s) and clearly indicate your work. Credit can be given **only** if your work is legible, clearly explained, and labelled.
9. All of the questions require you show your work and reasoning.
10. Have your TAMU ID ready when submitting your exam to the proctor.

Fill out the information below and sign to indicate  
your understanding of the above rules

Name: \_\_\_\_\_  
(printed *legibly*)

UIN: \_\_\_\_\_

Signature: \_\_\_\_\_

Section Number: \_\_\_\_\_

Instructor:  
(circle one)

Holt

Mioduszewski

Kocharovskya

Rogagchev



**Short Answers:****Short Answers:**

- A) A parallel-plate capacitor is connected to a battery with a terminal voltage,  $V$ . You slide a slab of dielectric with a dielectric constant  $\kappa$  between the plates such that the space between the plates is entirely filled with this dielectric. What effect does adding the dielectric have on i) the amount of charge on the capacitor plates and ii) on the energy stored in the capacitor? Support your answers by formulas and give a physical explanation.

LO	S	U
27.1		
28.1		
30.1		
31.1		

- B) Two cylindrical resistors are made from the same material and are equal in length. The first resistor has diameter  $d$ , and the second resistor has diameter  $2d$ .

If the same current flows through both, and the voltage across the first resistor is  $V$ , what is the voltage across the second resistor?

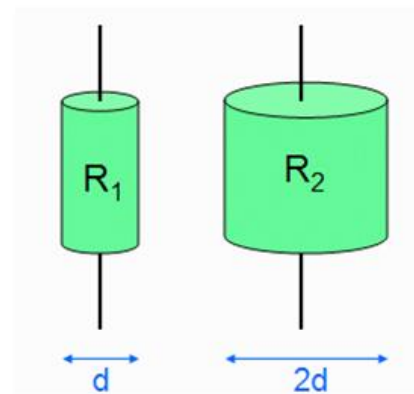

LO	S	U
3.1		
35.1		
36.1		

- C) An air filled parallel plate capacitor is made out of two circular plates of radius,  $R$ , separated by a distance,  $d$ . Initially the capacitor is connected to a battery with a terminal voltage,  $V$ . i) Find the charge on each plate after the plates have been connected to the battery. ii) If the battery is now disconnected without discharging the plates and then the plates separated by a distance,  $2d$ , find the voltage between the plates in this new configuration.

LO	S	U
27.2		
28.2		
5.1		
27.3		
28.3		

- D) A 120-V, 240-W light bulb (A), a 120-V, 120-W light bulb(B), and a 120-V, 60-W light bulb(C) are connected in series as shown. The voltage between points a and b is 120 V. Which bulb glows the brightest? Give a reason for your choice.

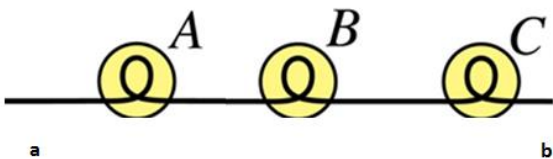

LO	S	U
3.2		
5.2		
39.1		
40.1		
45.1		

**Prob 1** In the circuit shown,  $R_1 = 2\Omega$ ,  $R_2 = 3\Omega$ ,  $R_3 = 6\Omega$ , and  $C = 2\mu F$ .

(a) Determine the potential difference  $V_C$  across the capacitor after switch S has been closed for a long time.

(b) Determine the energy stored in the capacitor after switch S has been closed for a long time.

(c) After the switch is opened, what is the time constant, the time it takes for the charge to drop to  $e^{-1}$ , for the discharging of the capacitor?

(d) Find the total current flowing through the resistors as a function of time after the switch is opened.

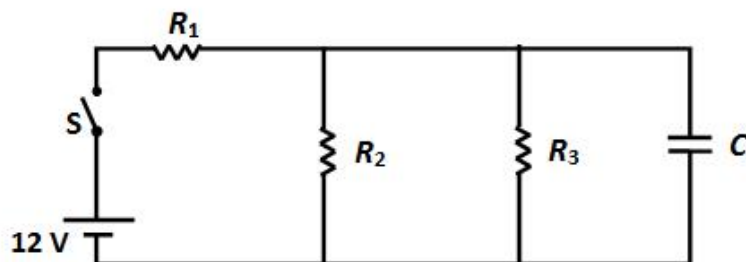

LO	S	U
3.3		
5.3		
38.1		
40.2		
41.1		
42.1		
44.1		
3.4		
30.2		
40.3		
44.2		
44.3		
6.1		





**Prob 2** For the system of capacitors shown, a potential difference of 50 V is maintained across the terminals a and b.

(a) What is the equivalent capacitance of this system between a and b?

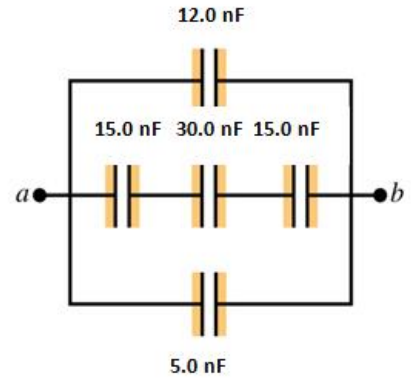

(b) How much charge is stored by this system?

(c) How much charge does the 5.0 nF capacitor store?

(d) What is the potential difference across the 30.0 nF capacitor?

LO	S	U
3.5		
29.1		
29.2		
27.4		
27.5		
29.3		



**Prob 3** For the DC circuit in figure below and with the switch S is open. Answer the following:

- (a) Calculate the currents through each resistor and indicate the direction that each is flowing.

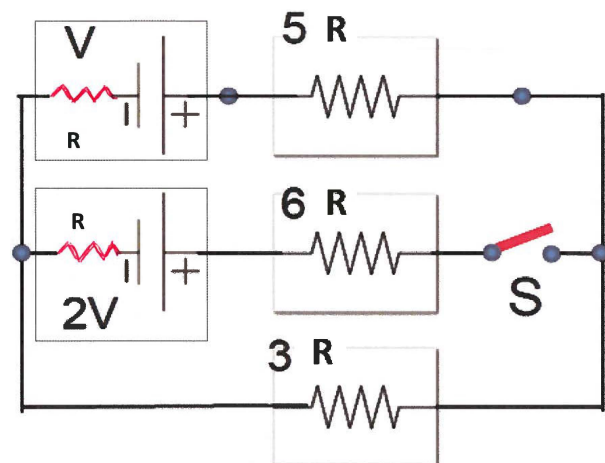

- (b) Calculate the voltage between two contacts of the open switch.

Now with the switch in this circuit closed answer the following:

- (c) Calculate the currents through each resistor and once again indicate the direction that each is flowing.

- (d) Calculate the power output of the battery with V voltage output (Note, the resistors in the dotted boxes around each battery are internal resistors).

LO	S	U
37.1		
38.2		
40.4		
41.2		
42.2		
4.1		
5.4		
42.3		
39.2		

---

Extra Space: