Physics 207 - Exam II

Spring 2020 (520-524; 525-529; 531-535) March 2, 2020.

Please fill out the information and read the instructions below, but
do not open the exam until told to do so.

Rules of the exam:

1. You have 75 minutes (1.25 hrs.) to complete the exam.
2. Formulae are provided to you with the exam on a separate sheet. Make sure you have one before the exam starts. You may not use any other formula sheet.
3. Check to see that there are 5 double-sided pages including the scantron-like cover page. Do not remove any pages.
4. If you run out of space for a given problem, the last page has been left blank and may be used for extra space. Be sure to indicate at the problem under consideration that the extra space is being utilized so the graders know to look at it!
5. **You will only be allowed to use a non-programmable calculator or a programmable calculator that has had its memory cleared on this exam.**
6. **NOTE** that you **must** show your work clearly to receive full credit.
7. Cell phone use during the exam is strictly prohibited. Please turn off all ringers as calls during an exam can be quite distracting.
8. Be sure to put a box around your final answer(s) and clearly indicate your work. Credit can be given only if your work is legible, clearly explained, and labelled.
9. All of the questions require you show your work and reasoning.
10. Have your TAMU ID ready when submitting your exam to the proctor.

Fill out the information below and sign to indicate your understanding of the above rules

Name: _____
(Printed legibly)

UIN: _____

Signature: _____

Section Number: _____

Instructor: McIntyre Ross Webb
(circle one)

- A. For the circuit shown in the figure below, answer the following in terms of the quantities given (C_1 , C_2 , C_3 , and V_{ext}):
- The equivalent capacitance for the network shown in the figure.
 - The charge stored on C_1 and C_2 respectively when a voltage V_{ext} is applied to the network as shown.
 - The voltage across each capacitor from part b).
 - The total stored energy in the system for all capacitors when this voltage is applied.

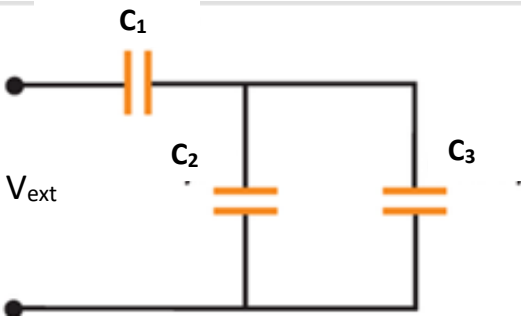

LO	P	F
3.1		
28.1		
28.2		
28.3		
28.4		
30.1		
30.1		
31.1		

B. Given the resistor network below, answer the following:

- a) What is the effective resistance of this network?
- b) If a 10.0 V battery is connected between points *a* and *b* in the circuit, find the current flowing in the 24 Ω resistor.

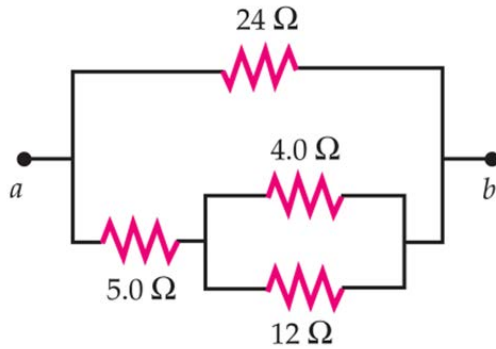

LO	P	F
3.2		
36.1		
36.2		
36.3		
36.4		
37.1		

C. An automotive battery has an emf of 12.0 V. When supplying power to the starter motor, the current in the battery is 200 A and the terminal voltage of the battery is 11.0 V.

- a) What is the internal resistance of the battery?
- b) What is the electric power that is delivered to the starter motor?

LO	P	F
3.3		
5.1		
37.2		
39.1		
40.1		

Problem I.

Two thin-walled concentric conducting spheres of radii R_1 and R_2 separated by vacuum have a potential difference of V_o between them. Answer the following in terms of known constants and the quantities given (R_1 , R_2 , and V_o).

- a) Starting from the definition of capacitance, derive an expression for the capacitance of this combination?
- b) What is the charge carried by each sphere?
- c) How much energy is stored in the capacitor under these conditions?

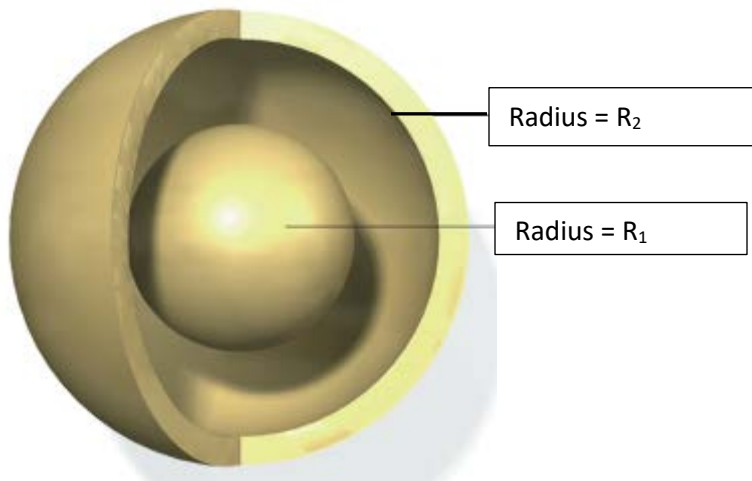

LO	P	F
3.4		
24.1		
28.5		
28.6		
29.1		
31.2		

Problem II.

Given the circuit below, answer the following:

- Write an expression for all the currents flowing into and out of the junction labeled *a* in the figure.
- Using the two loops shown in the figure and the current definitions from part a), write down the loop equation for each loop.
- Solve for the currents flowing through each of the three batteries in the circuit.

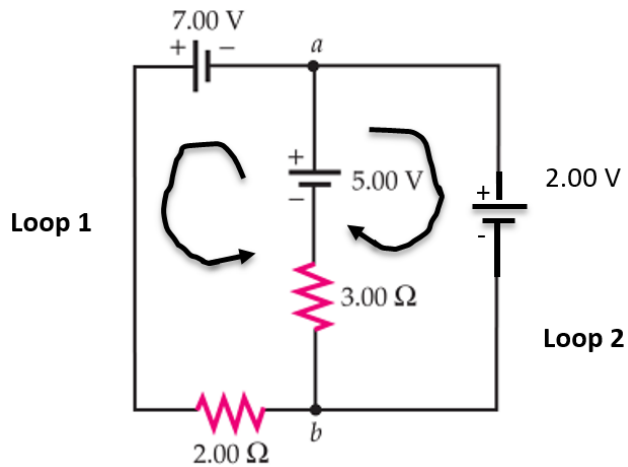

LO	P	F
3.5		
4.1		
4.2		
4.3		
43.1		
43.2		
43.3		

Problem III.

An uncharged capacitor with capacitance C is connected in series with a resistor R , a battery, and an open switch. The battery has an internal resistance of r and the open-circuit voltage across its terminals is \mathcal{E} . The leads have no appreciable resistance. At time $t = 0$, the switch is suddenly closed. In terms of the quantities given, answer the following:

- What is the maximum current through the resistor labelled R ?
- What is the maximum charge that the capacitor receives?
- When the current in the circuit is I , how much charge is on the plates of the capacitor?
- How long will it take from the time the switch is closed for the capacitor to reach one third of its final charge?

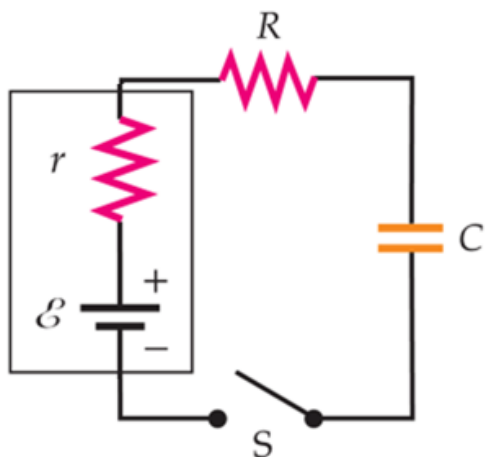

LO	P	F
3.6		
43.4		
43.5		
43.6		
45.1		
45.2		
45.3		
45.4		