

---

# Physics 207 - Exam III

Fall 2019 (207-210, 543-566; 579-584) November 11, 2019.

---

Please fill out the information and read the instructions below, but  
**do not open the exam** until told to do so.

Rules of the exam:

1. You have 75 minutes (1.25 hrs) to complete the exam.
2. Formulae are provided to you with the exam on a separate sheet. Make sure you have one before the exam starts. You may not use any other formula sheet.
3. Check to see that there are 6 numbered (3 double-sided) pages plus a blank page for additional work if needed, in addition to the scantron-like cover page. Do not remove any pages.
4. If you run out of space for a given problem, the last page has been left blank and may be used for extra space. Be sure to indicate at the problem under consideration that the extra space is being utilized so the graders know to look at it!
- 5. You will be allowed to use only non-programmable calculators on this exam.**
6. **NOTE** that you **must** show your work clearly to receive full credit.
7. Cell phone use during the exam is strictly prohibited. Please turn off all ringers as calls during an exam can be quite distracting.
8. Be sure to put a box around your final answer(s) and clearly indicate your work. Credit can be given only if your work is legible, clearly explained, and labelled.
9. All of the questions require you show your work and reasoning.
10. Have your TAMU ID ready when submitting your exam to the proctor.

**Fill out the information below and sign to indicate your understanding of the above rules**

Name: \_\_\_\_\_  
(printed legibly)

UIN: \_\_\_\_\_

Signature: \_\_\_\_\_

Section Number: \_\_\_\_\_

Instructor:    Webb        Kocharovskaya        Saslow        Eusebi  
**(circle one)**

A. The wires below are placed in a homogenous external magnetic field  $\vec{B}$  and carry a current  $I$  in the directions indicated. In each case indicate the direction of the force felt by the wire by placing an  $\hat{x}$ ,  $\hat{y}$ ,  $\hat{z}$  or 0 for no force according to the coordinate system at the right of the figure.

a)

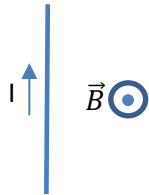

b)

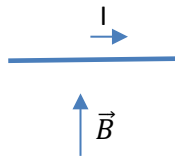

c)

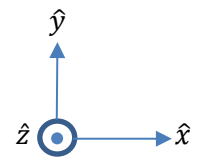

LO	P	F
2.1		
3.1		
49.1		
49.2		
49.3		

**B.** A device produces a homogenous magnetic field of magnitude  $\mathbf{B}_0$  in the center region and of magnitude  $\mathbf{B}_1$  outside the center in the directions depicted below. Find  $\oint \vec{B} \cdot d\vec{l}$  (also known as “circulation” of  $\vec{B}$ ) for the three “Amperian” loops shown in the figure. Each loop is a rectangle of dimensions  $H$  (short side) and  $W$  (long side).

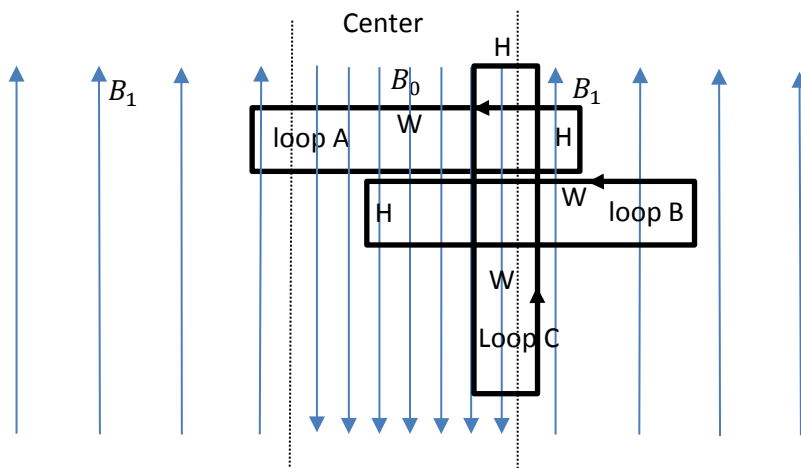

Answers:

$$\oint_{loop A} \vec{B} \cdot d\vec{l} =$$

$$\oint_{loop B} \vec{B} \cdot d\vec{l} =$$

$$\oint_{loop C} \vec{B} \cdot d\vec{l} =$$

LO	P	F
2.2		
3.2		
7.1		
7.2		
7.3		
47.1		
47.2		
47.3		

C. In each case below an object with a charge  $q = 1\text{ C}$  moves with velocity  $\vec{v}$  inside a region of electric field  $\vec{E}$  and magnetic field  $\vec{B}$  with values and directions as shown in the figures below. Find the force vector felt by the object in each of these three situations.

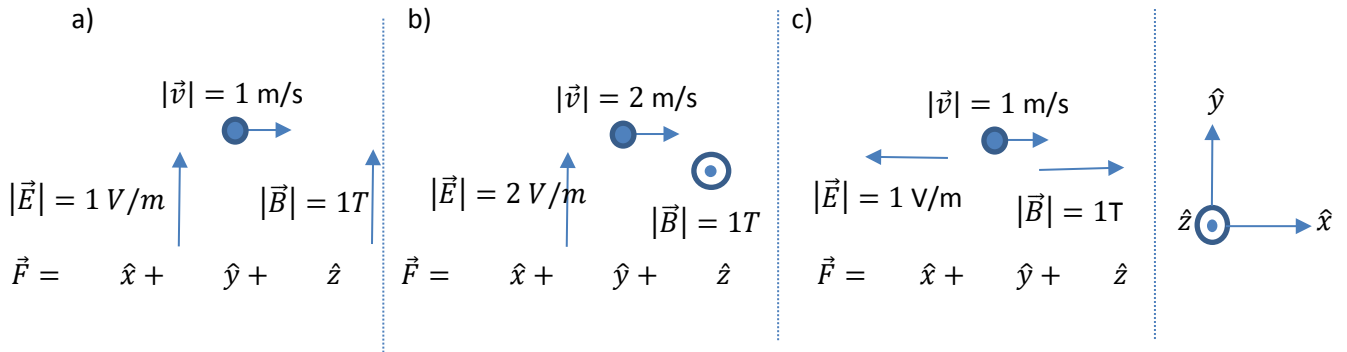

LO	P	F
2.3		
3.3		
11.1		
11.2		
11.3		
46.1		
46.2		
46.3		

**Problem I.**

Two currents  $I_1$  and  $I_2$  flow in the upper and lower wires shaped into half circles of the same radius  $R$  as shown below. Note that you are to neglect the size of the wires shown in the figure and consider them as “lines” of current on top of one another. If  $I_2 = 2I_1$  answer the following:

- Find the magnitude *and* direction of the magnetic field at the point P due to the two wires coming in from negative infinity to the point S.
- Find the magnitude *and* direction of the magnetic field at the point P due to the two wires as they carry current out to positive infinity from the point T.
- Find the magnitude *and* direction of the magnetic field at the point P due to the two wire loops.
- Find the magnitude *and* direction of the magnetic force acting on an electron passing point P with the velocity  $v$  directed to the left.

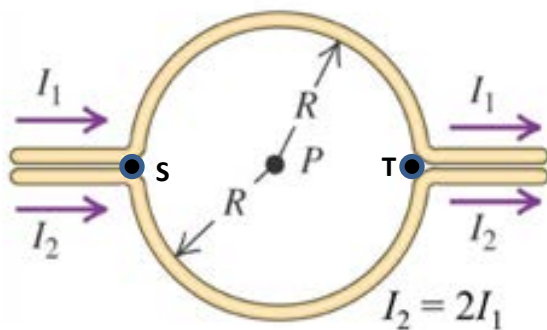

LO	P	F
2.4		
3.4		
7.4		
46.4		
52.1		
52.2		
52.3		

**Problem II.**

The figure below shows the **view from above** a rectangular loop of wire located in a uniform magnetic field that is perpendicular to the plane of the loop (**neglect gravity**). One side of this loop is a “slide wire” of length  $l$  and resistance  $R$  that can move without friction along the rails. Neglect the resistance of the loop, except for the “slide wire”. A constant force,  $F$ , is applied to the “slide wire” causing it to move with constant velocity,  $v_0$ . In terms of the quantities given, answer the following:

- Find the induced *emf* and the induced current,  $I$ , flowing in the loop as the “slide wire” moves with velocity,  $v_0$ .
- Indicate in the figure the direction of the induced current.
- Draw a “free body” diagram for the “slide wire”.
- In terms of the other given quantities, find the value of the force,  $F$  that must be applied to the “slide wire”.

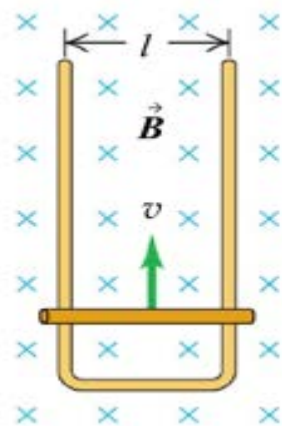

LO	P	F
3.5		
7.5		
37.1		
49.4		
56.1		
57.1		
58.1		

**Problem III.**

Consider the circuit below containing a 50V battery with  $R_1 = 30.0 \Omega$ ,  $R_2 = 20.0 \Omega$  and  $L = 0.40 \text{ H}$  as shown. At  $t = 0$  the switch is closed.

- Find currents *and* voltages across all elements **just after  $t = 0$**  ( $i$ ,  $i_1$ ,  $i_2$ ,  $V_{ab}$ ,  $V_{ac}$ , and  $V_{cd}$ ).
- Find currents *and* voltages across all elements after the switch is closed **for a long time** ( $i$ ,  $i_1$ ,  $i_2$ ,  $V_{ab}$ ,  $V_{ac}$ , and  $V_{cd}$ ).
- After the switch has been closed for a long time it is reopened. Find currents *and* voltages **just after reopening** the switch ( $i$ ,  $i_1$ ,  $i_2$ ,  $V_{ab}$ ,  $V_{ac}$ , and  $V_{cd}$ ).

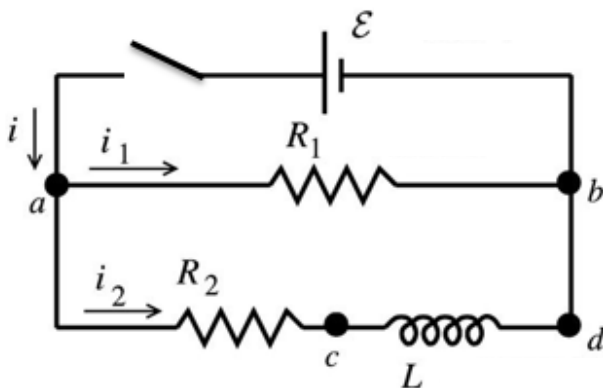

LO	P	F
3.6		
38.1		
43.1		
43.2		
43.3		
43.4		
58.2		
65.1		
65.2		
65.3		